

KS B1503 FLANGE STANDARD 30K SLIP ON FLANGE

NOMINAL SIZE 10 - 50mm (TYPE B)

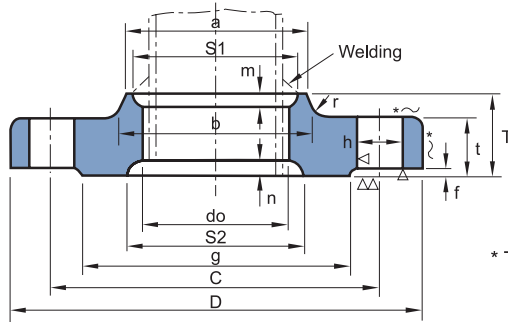

NOMINAL SIZE 65 - 400mm (TYPE C)

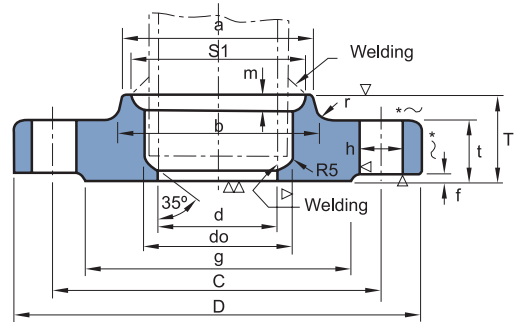

* The surface finish (~) is in the case of die forging.

Unit : mm

Nominal Pipe Size	Outside Diam. of Flanges D	Sectional Dimensions of Flange													Reference					
		Bolt Circle Dia. C	Dia. of Raised Face g	Inside Dia. of Steel Pipe	Outside Dia. of Steel pipe	t	T	Dia. of Hub		Radius r	f	d	Number of Bolt Holes	Holes Dia. h	Nominal Bolt Size	S1	m	S2	n	l
								a	b											
10	110	75	52	17.8	17.3	16	24	30	34	4	1	-	4	19	M16	-	-	-	-	-
15	115	80	55	22.2	21.7	18	26	36	40	5	1	-	4	19	M16	31	4	40	5	-
20	120	85	60	27.7	27.2	18	28	42	46	5	1	-	4	19	M16	37	5	44	5	-
25	130	95	70	34.5	34.0	20	30	50	54	5	1	-	4	19	M16	55	6	52	5	-
32	140	105	80	43.2	42.7	22	32	60	64	6	2	-	4	19	M16	52	6	60	5	-
40	160	120	90	49.1	48.6	22	34	66	70	6	2	-	4	23	M20	58	6	66	5	-
50	165	130	105	61.1	60.5	22	36	82	86	6	2	-	8	19	M16	70	6.5	78	5	-
65	200	160	130	77.1	76.3	26	40	102	106	8	2	65.9	8	23	M20	96	9.5	94	5	6
80	210	170	140	90.0	89.1	28	44	115	121	8	2	78.1	8	23	M20	109	9.5	-	-	6
(90)	230	185	150	102.6	101.6	30	46	128	134	8	2	90.2	8	25	M22	122	9.5	-	-	6
100	240	195	160	115.4	114.3	32	48	141	147	8	2	102.3	8	25	M22	135	9.5	-	-	6
125	275	230	195	141.2	139.8	36	54	166	172	8	2	126.6	8	25	M22	160	9.5	-	-	6
150	325	275	235	166.6	165.2	38	58	196	204	8	2	151.0	12	27	M24	186	9.5	-	-	6
200	370	320	280	218.0	216.3	42	64	248	256	8	2	199.9	12	27	M24	237	9.5	-	-	6
250	450	390	345	269.5	267.4	48	72	306	314	10	2	248.8	12	22	M30	290	10	-	-	6
300	515	450	405	321.0	318.5	52	78	360	370	10	3	297.9	16	33	M30	345	12	-	-	6
350	560	495	450	358.1	355.6	54	84	402	412	12	3	333.4	16	33	M30	383	13	-	-	6
400	630	560	510	409.0	406.4	60	92	456	468	15	3	381.0	16	39	M36	435	14	-	-	7

NOTE:

- Flanges of parenthesized nominal diameter (), not to be used unless otherwise noted by purchaser.
- "d" is an example of pipe thickness for schedule 40 for nominal diameter 400 and under, and for schedule 12.7 mm for 450 through 600 of KS B3562 and KS D3507 (JIS G3454, JIS G3456)