

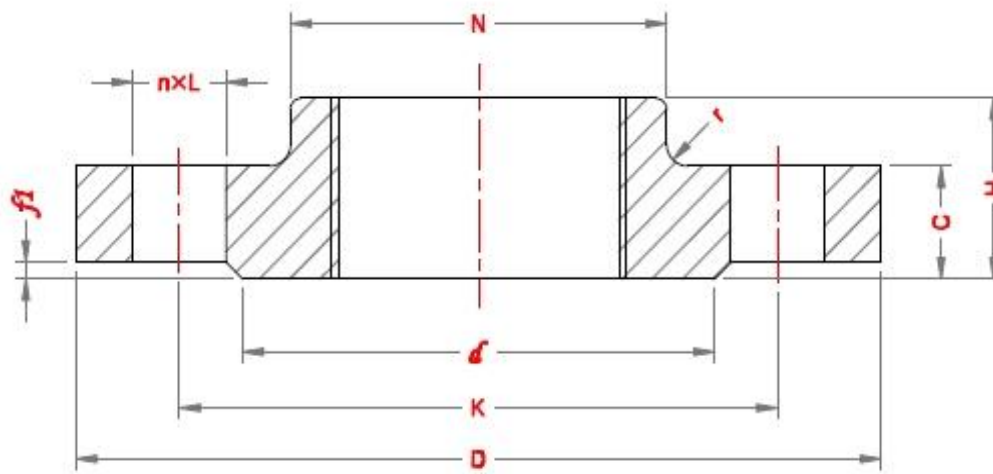

Threaded Flanges - EN1092-1



PN 40

DN	Pipe OD, A	Outside Diameter, D	Diameter of Bolt Circle, K	Dia of Bolt Hole, L	No. of bolt	Diameter of Raised Face, d	Height of Raised Face, f1	Flange thickness, C	Length of Flange, H	Neck Diameter, N	Radius of Corners, r
10	17.2	90	60	14	4	40	2	16	22	30	4
15	21.3	95	65	14	4	45	2	16	22	35	4
20	26.9	105	75	14	4	58	2	18	26	45	4
25	33.7	115	85	14	4	68	2	18	28	52	4
32	42.4	140	100	18	4	78	2	18	30	60	6
40	48.3	150	110	18	4	88	3	18	32	70	6
50	60.3	165	125	18	4	102	3	20	34	84	6
65	76.1	185	145	18	8	122	3	22	38	104	6
80	88.9	200	160	18	8	138	3	24	40	118	8
100	114.3	235	190	22	8	162	3	24	44	145	8
125	139.7	270	220	26	8	188	3	26	48	170	8
150	168.3	300	250	26	8	218	3	28	52	200	10
200	219.1	375	320	30	12	285	3	34	52	260	10
250	273	450	385	33	12	345	3	38	60	312	12
300	323.9	515	450	33	16	410	4	42	67	380	12
350	355.6	580	510	36	16	465	4	46	72	424	12
400	406.4	660	585	39	16	535	4	50	78	478	12
450	457	685	610	39	20	560	4	57	84	522	12
500	608	755	670	42	20	615	4	57	90	576	12
600	610	890	795	48	20	735	5	72	100	686	12