

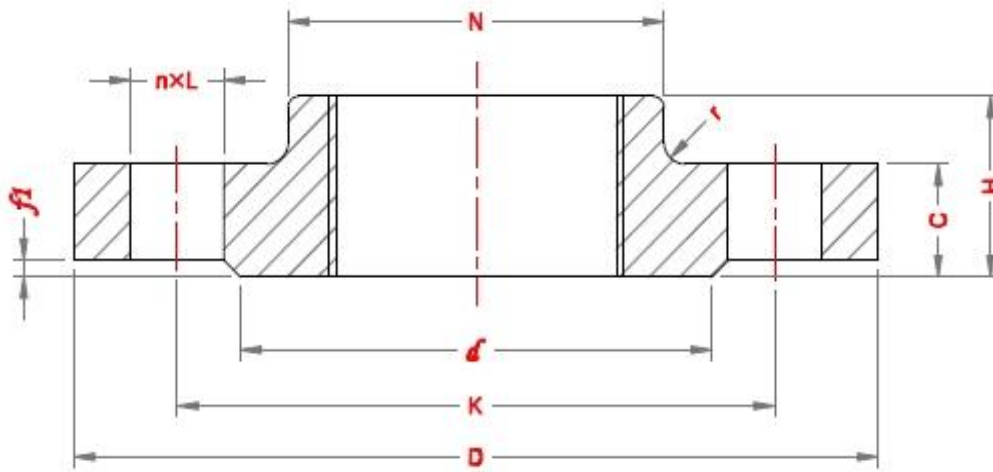

Threaded Flanges - EN1092-1



PN 25

DN	Pipe OD, A	Outside Diamete, D	Diameter of Bolt Circle, K	Dia of Bolt Hole, L	No. of bolt	Diameter of Raised Face, d	Height of Raised Face, f1	Flange thickness, C	Length of Flange, H	Neck Diameter, N	Radius of Corners, r
10	17.2	90	60	14	4	40	2	16	22	30	4
15	21.3	95	65	14	4	45	2	16	22	35	4
20	26.9	105	75	14	4	58	2	18	26	45	4
25	33.7	115	85	14	4	68	2	18	28	52	4
32	42.4	140	100	18	4	78	2	18	30	60	6
40	48.3	150	110	18	4	88	3	18	32	70	6
50	60.3	165	125	18	4	102	3	20	34	84	6
65	76.1	185	145	18	8	122	3	22	38	104	6
80	88.9	200	160	18	8	138	3	24	40	118	8
100	114.3	235	190	22	8	162	3	24	44	145	8
125	139.7	270	220	26	8	188	3	26	48	170	8
150	168.3	300	250	26	8	218	3	28	52	200	10
200	219.1	360	310	26	12	278	3	30	52	256	10
250	273	425	370	30	12	335	3	32	60	310	12
300	323.9	485	430	30	16	395	4	34	67	364	12
350	355.6	555	490	33	16	450	4	38	72	418	12
400	406.4	620	550	36	16	505	4	40	78	472	12
450	457	670	600	36	20	555	4	46	84	520	12
500	508	730	660	36	20	615	4	48	90	580	12
600	610	845	770	39	20	720	5	48	100	684	12