

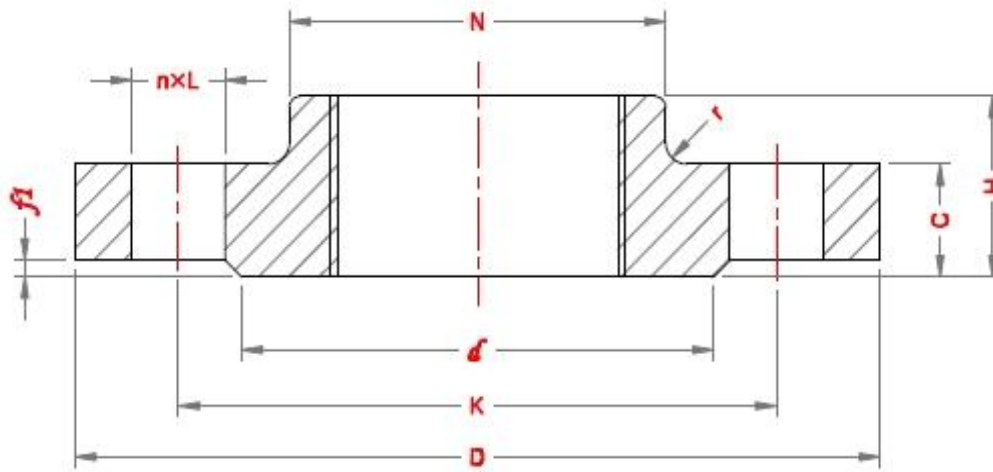

Threaded Flanges - EN1092-1



PN 10

DN	Pipe OD, A	Outside Diamete, D	Diameter of Bolt Circle, K	Dia of Bolt Hole, L	No. of bolt	Diameter of Raised Face, d	Height of Raised Face, f1	Flange thickness, C	Length of Flange, H	Neck Diameter, N	Radius of Corners, r
10	17.2	90	60	14	4	40	2	16	22	30	4
15	21.3	95	65	14	4	45	2	16	22	35	4
20	26.9	105	75	14	4	58	2	18	26	45	4
25	33.7	115	85	14	4	68	2	18	28	52	4
32	42.4	140	100	18	4	78	2	18	30	60	6
40	48.3	150	110	18	4	88	3	18	32	70	6
50	60.3	165	125	18	4	102	3	18	28	84	6
65	76.1	185	145	18	8	122	3	18	32	104	6
80	88.9	200	160	18	8	138	3	20	34	118	6
100	114.3	220	180	18	8	158	3	20	40	140	8
125	139.7	250	210	18	8	188	3	22	44	168	8
150	168.3	285	240	22	8	212	3	22	44	195	10
200	219.1	340	295	22	8	268	3	24	44	246	10
250	273	395	350	22	12	320	3	26	46	298	12
300	323.9	445	400	22	12	370	4	26	46	350	12
350	355.6	505	460	22	16	430	4	26	53	400	12
400	406.4	565	515	26	16	482	4	26	57	456	12
450	457	615	565	26	20	532	4	28	63	502	12
500	508	670	620	26	20	585	4	28	67	559	12
600	610	780	725	30	20	685	5	30	75	658	12