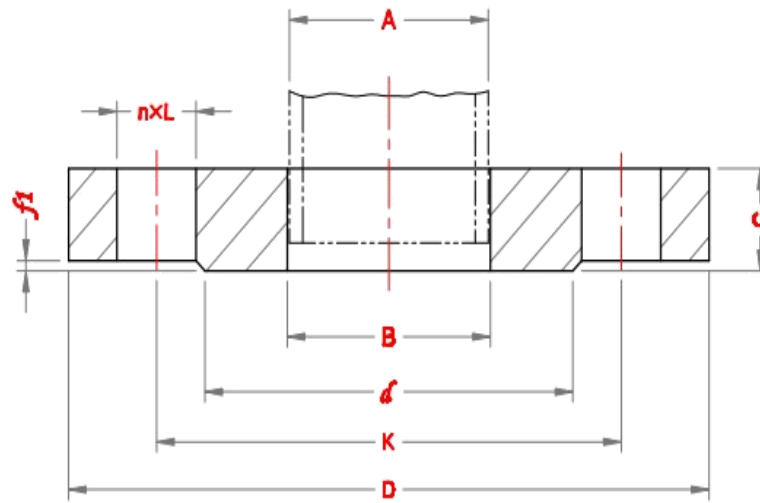

Plate Flanges - EN1092-1



PN 63

DN	Pipe OD, A		Outside Diameter, D	Diameter of Bolt Circle, K	Dia of Bolt Hole, L	No. of bolt	Size of Bolt	Flange thickness, C	Diameter of Raised Face, d	Height of Raised Face, f1	Bore diameter, B	
	Series I	Series II									Series I	Series II
10	17.2	14	100	70	14	4	M12	20	40	2	18	15
15	21.3	18	105	75	14	4	M12	20	45	2	22	19
20	26.9	25	130	90	18	4	M16	22	58	2	27.5	26
25	33.7	32	140	100	18	4	M16	24	68	2	34.5	33
32	42.4	38	155	110	22	4	M20	24	78	2	43.5	39
40	48.3	45	170	125	22	4	M20	26	88	3	49.5	46
50	60.3	57	180	135	22	4	M20	26	102	3	61.5	59
65	76.1	79	205	160	22	8	M20	26	122	3	77.5	78
80	88.9	89	215	170	22	8	M20	30	138	3	90.5	91
100	114.3	108	250	200	26	8	M24	32	162	3	116	110
125	139.7	133	295	240	30	8	M27	34	188	3	141.5	135
150	168.3	159	345	280	33	8	M30	36	218	3	170.5	161
200	219.1	219	415	345	36	12	M33	48	285	3	221.5	222
250	273	273	470	400	36	12	M33	55	345	3	276.5	276
300	323.9	325	530	460	36	16	M33	65	410	4	327.5	328
350	355.6	377	600	525	39	16	M36	72	465	4	359.5	380
400	406.4	426	670	585	42	16	M39	80	535	4	411	430