

Hubbed slip-on Flanges

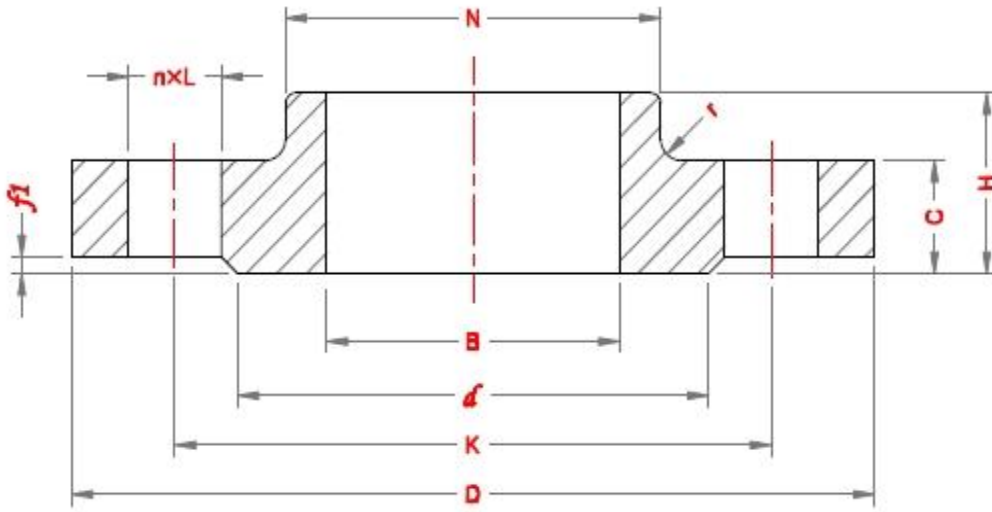

PN 63

DN	Pipe OD, A		Outside Diameter, D	Diameter of Bolt Circle, K	Dia of Bolt Hole, L	No. of bolt	Diameter of Raised Face, d	Height of Raised Face, f1	Flange thickness, C	Length of Flange, H	Neck Diameter, N		Radius of Corners, r	Bore diameter, B	
	Series I	Series II									Series I	Series II		Series I	Series II
10	17.2	14	100	70	14	4	40	2	20	28	40	4	18	15	
15	21.3	18	105	75	14	4	45	2	20	28	43	4	22	19	
20	26.9	25	130	90	18	4	58	2	20	30	52	4	27.5	26	
25	33.7	32	140	100	18	4	68	2	24	32	60	4	34.5	33	
32	42.4	38	155	110	22	4	78	2	24	32	68	6	43.5	39	
40	48.3	45	170	125	22	4	88	3	26	34	80	6	49.5	46	
50	60.3	57	180	135	22	4	102	3	26	36	90	6	61.5	59	
65	76.1	79	205	160	22	8	122	3	26	40	112	6	77.5	78	
80	88.9	89	215	170	22	8	138	3	28	44	125	8	90.5	91	
100	114.3	108	250	200	26	8	162	3	30	52	152	8	116	110	
125	139.7	133	295	240	30	8	188	3	34	56	185	8	141.5	135	
150	168.3	159	345	280	33	8	218	3	36	60	215	10	170.5	161	