

Weld Neck Flanges - EN 1092-1

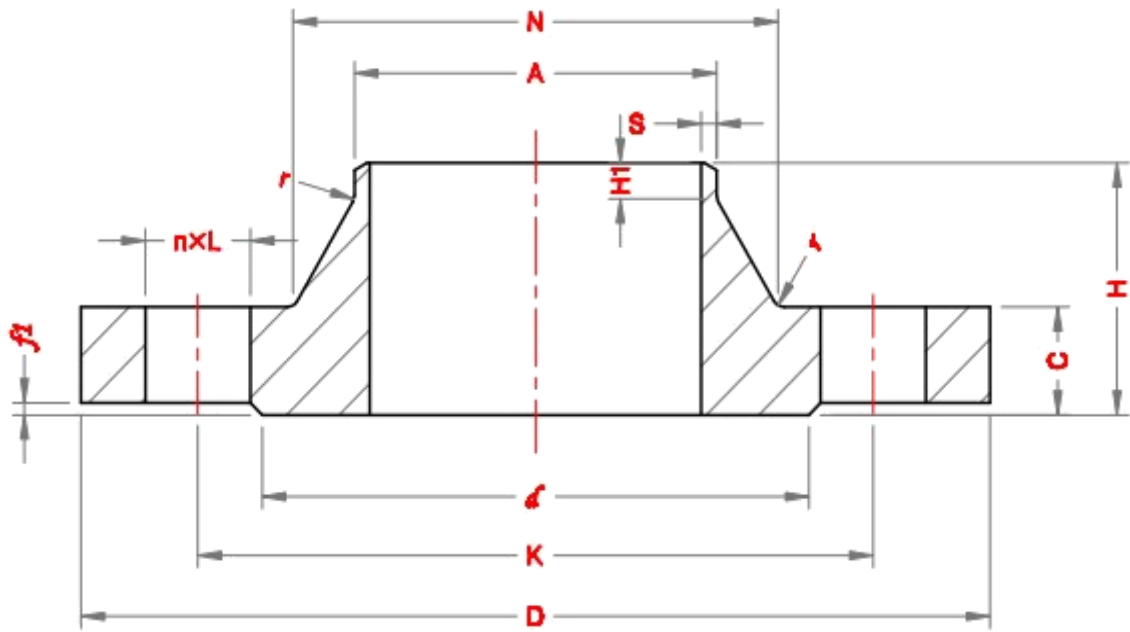

PN 400

DN	Pipe OD, A	Outside Diameter, D	Diameter of Bolt Circle, K	Diameter of Bolt Holes, L	No. of bolts	Diameter of Raised Face, d	Height of Raised Face, f1	Flange thick, C	Length of Flange, H	Neck Diameter, N	Wall thick, S	Length of right end, H1	Radius of Corners, r
10	17.2	125	85	18	4	40	2	28	65	48	3.6	8	4
15	26.9	145	100	22	4	45	2	30	68	56	5.0	8	4
20	33.7	160	115	22	4	58	2	34	80	70	6.3	10	4
25	42.4	180	130	26	4	68	2	38	90	82	7.1	10	4
32	48.3	200	145	26	4	78	2	43	100	94	8.8	12	6
40	60.3	220	165	30	4	88	3	48	110	106	10.0	12	6
50	76.1	235	180	30	8	102	3	52	120	120	12.5	15	6
65	101.6	290	225	33	8	122	3	64	135	158	16.0	18	6
80	114.3	305	240	33	8	138	3	68	150	174	17.5	20	8
100	139.7	370	295	39	8	162	3	80	175	216	22.2	25	8
125	193.7	415	340	39	12	188	3	92	200	258	30.0	30	8
150	219.1	475	390	42	12	218	3	105	225	302	35.0	35	10
200	273	585	490	48	16	285	3	130	280	388	40.0	40	10